

ProTape®

3000V DISPENSER

Instruction Manual

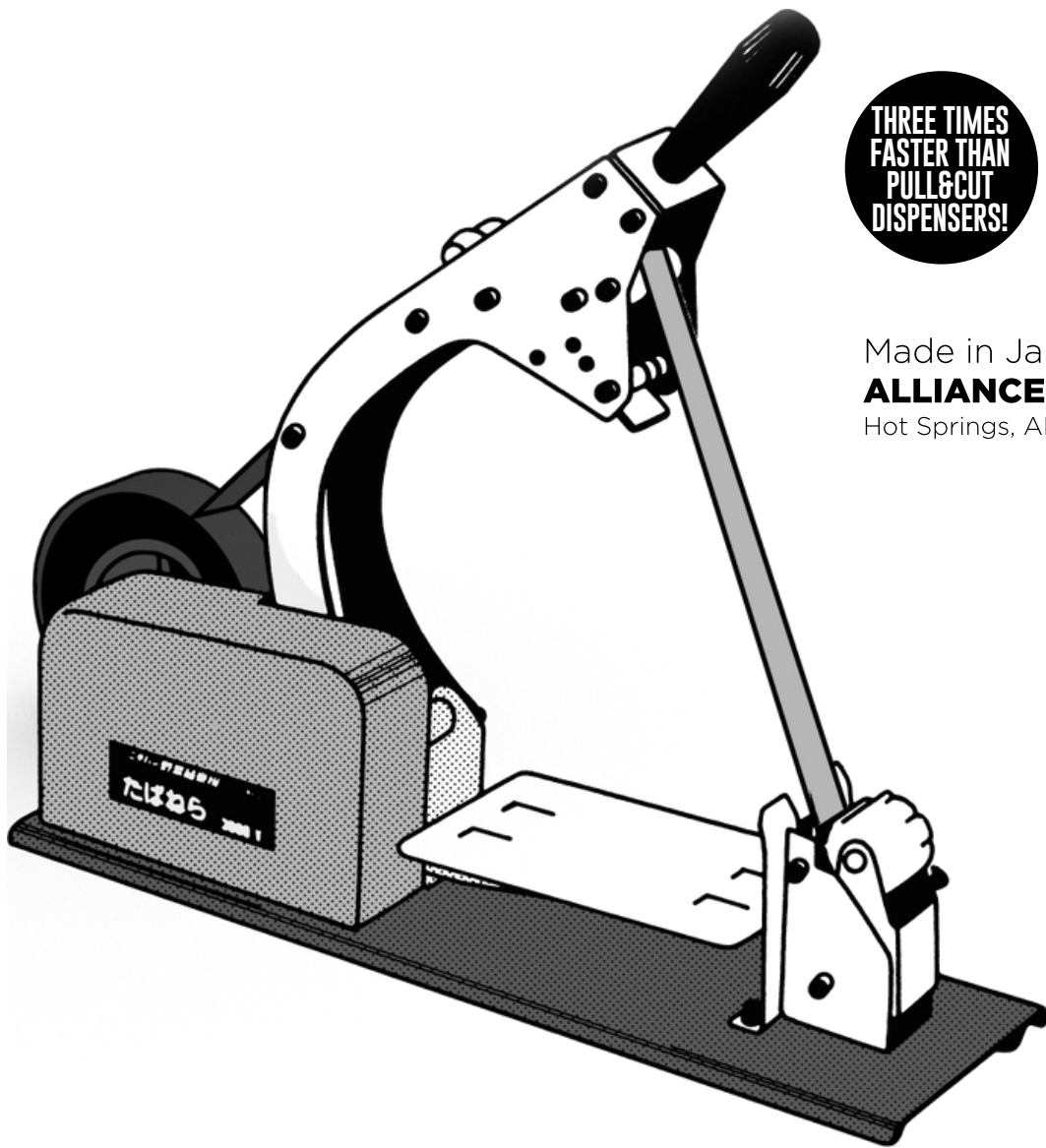

THREE TIMES
FASTER THAN
PULL & CUT
DISPENSERS!

MEASURES,
WRAPS, AND
SEALS

Made in Japan Exclusively for:
ALLIANCE RUBBER COMPANY
Hot Springs, AR



ProTape® 3000V DISPENSER

Instruction Manual

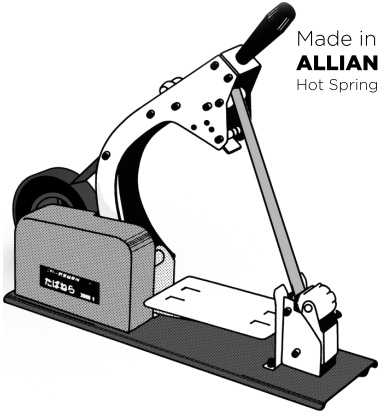

Made in Japan Exclusively for:
ALLIANCE RUBBER COMPANY
Hot Springs, AR

THREE TIMES
FASTER THAN
PULL & CUT
DISPENSERS!

MEASURES,
WRAPS, AND
SEALS

Product Features

With the push of a hand this semi-automatic dispenser measures, wraps, and seals ProTape® to make a secure and attractive bundle.

Point 1 Versatile



The 3000V features an adjustable receptacle plate which allows you to accommodate produce in a wide range of sizes and still achieve the same tight bundle.

Point 2 Efficient

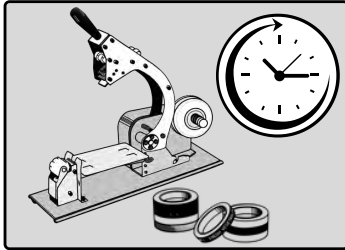

In comparison to other pull and cut dispensers, the 3000V is three times faster which means more produce sent to market at the end of the day.

Point 3 Durable

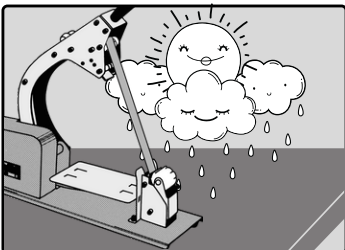

The 3000V is extremely durable for all types of outdoor applications. It can be operated during just about any type of weather - rain or shine!

Point 4 Easy to Operate

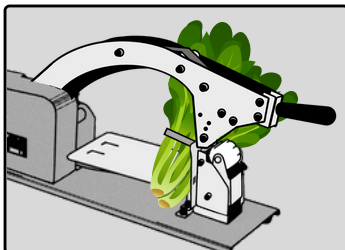

The open plate design of the 3000V makes bundling a breeze! It measures, wraps, and seals all in one.

Contents

3000V Dispenser	1
Blade Removal Pliers	1
Replacement Blades	2
Allen Wrenches	2
Mineral Oil	1
Arm Return Springs	2
Arm Return Spring Pin	1
Socket Head Cap Screws	2
Instruction Manual	1

NOT INCLUDED:

You will need the following items to assemble your 3000V Dispenser:



Basic Parts Overview

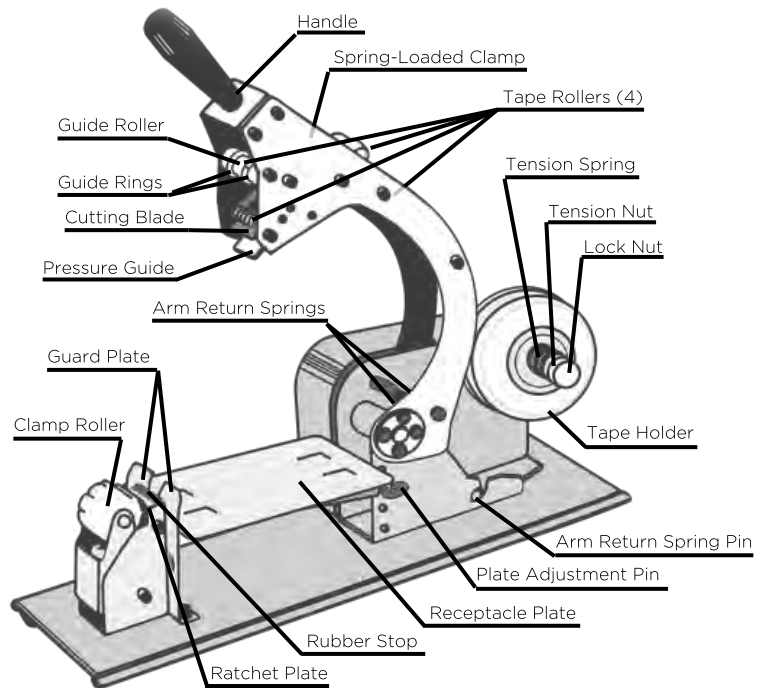

Specifications

Product Name	ProTape® Dispenser
Model	3000V
Dimensions	19" x 6" x 19.5" (when open) 19" x 6" x 9" (when closed for storage)
Weight	17.5 lbs.
Body Color	Orange
Accessories	Replacement Cutting Blades Tight Bundling Unit

1 Safety Information

Thank you for purchasing the ProTape® 3000V Dispenser. Please be sure to read through this instruction manual before using the product, and follow directions, paying attention to the safety precautions.

If you have any questions about this product, consult your customer service representative at Alliance Rubber Company.

■ Safety Precautions

This instruction manual contains safety precautions as shown below. These are designed to ensure safe use of the product and prevent danger or injury to yourself and others.

⚠ Caution

Failure to use the product as instructed could cause injury or damage to property.

⚠ Caution

- Test before use. Do not continue using the product if it does not operate as expected.
- Do not leave the product on a high shelf or unstable surface where it could fall and cause injury or damage to the product or other property.
- Do not leave the product in high-temperature, high-humidity conditions or in direct sunlight for prolonged periods. Exposure to such conditions can cause the plastic components to degrade and/or become deformed and could cause breakage or failure.
- Store the product in a safe place out of reach of children.

2 ProTape®



Product Name	ProTape®	
Size Options	12mm x 100m 15mm x 100m 20mm x 100m 24mm x 100m 30mm x 100m	
Pieces in Box	10 Rolls	20 Rolls
	15 mm 20 mm 24 mm 30 mm	12 mm
Materials	Base Material = Polypropylene Adhesive = Rubber	

3 Assembling the 3000V

⚠ Caution

- Use only genuine ProTape®
- Keep hands clear of the cutting blade to avoid injury.

- Use only the supplied parts.

- 1 After removing your 3000V Dispenser from the box, you will need to secure the Handle in place. Use the **Socket Head Cap Screw** supplied with the kit. *The handle may be tilted 15° for the most comfortable position.*

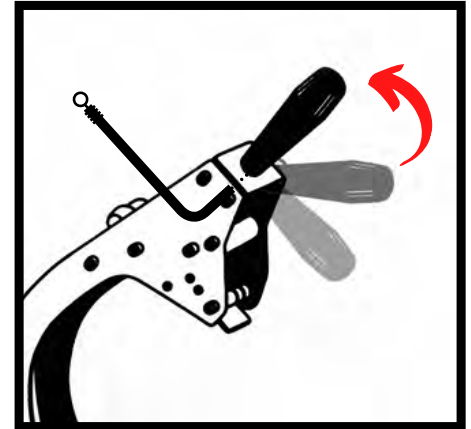

✓ NOTE:

Use the Allen Wrench to tighten the rest of the socket head screws throughout the 3000V Dispenser.

- 2 Next, locate the two **Arm Return Springs** (on the base of the handle). Turn the handle to the full upright position. Insert the **Arm Return Spring Pin** through the loops at the end of the two return springs, aligning them into the grooves. Next push the **Arm Return Spring Pin** down into the J-shaped holes in the arm bracket below it.

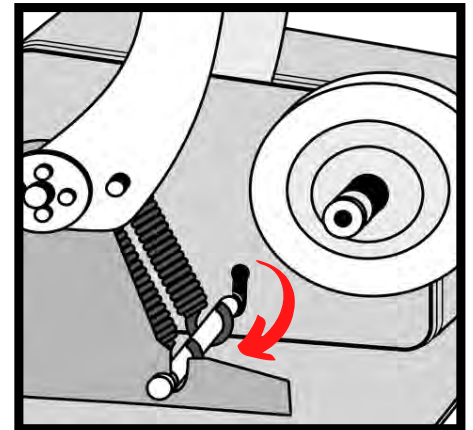

DID YOU KNOW?

Instructional videos are available online.

To watch these videos visit: www.RUBBERBAND.com and click on the "Produce, Floral, & Grocers Page" to find the model of your ProTape® dispenser.

As always, please do not hesitate to contact your sales rep if you have any questions or need assistance with any of our ProTape® products. Contact information can be found on the front cover of this manual.

Continued on next page

4 Installing ProTape®

Caution

- Use only genuine ProTape®
- Keep hands clear of the cutting blade to avoid injury.

- Use only the supplied parts.

1 The Guide Roller and Guard Plate are set to fit 20mm wide ProTape®. If you plan to use other sizes, adjust as follows:

A. Adjust Guide Rings on Guide Roller

Insert a flat blade screwdriver into the slot of the Guide Rings, opening just enough to slide left or right. The grooves on the Guide Roller are set for 10mm, 15mm, 20mm, and 30mm width ProTape®.

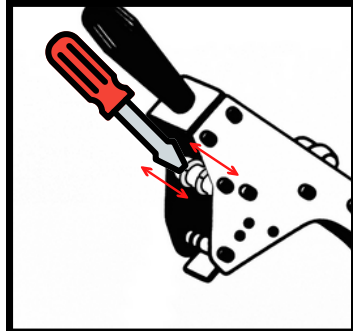

B. Adjust Guard Plate

Loosen the bolts on the Guard Plate using the supplied allen wrench. Adjust to the width tape being used.

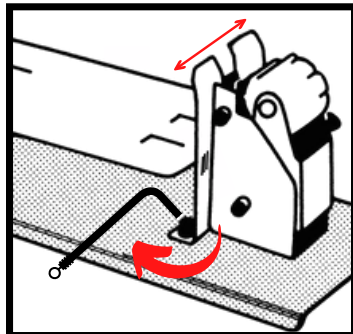

NOTE:

Use the engraved lines on the front of each Guard Plate as a guide for 12mm, 15mm, 30mm, etc.

2 Adjust the tab on the Tape Holder so it grips the tape core firmly. Push the roll of ProTape® onto the Tape Holder with the adhesive side up.

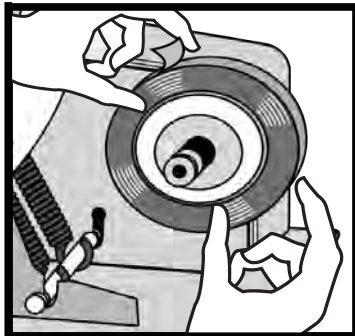

3 For normal use, feed ProTape® over Tape Rollers 1,2,3, and 4 (in that order).

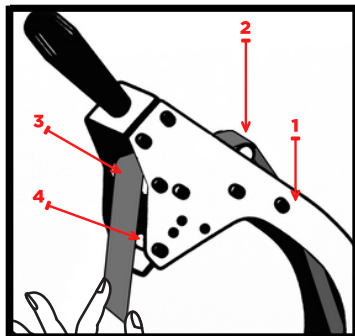

REMEMBER:

The ProTape® should feed over the Tape Rollers with the adhesive side up.

NOTE:

For large diameter bundles or when more tension is required, feed the tape under Tape Roller 1 and then over Tape Rollers 2, 3, and 4.

4 With one hand, pull the end of the ProTape® down until it touches the middle of the Receptacle Plate.

While still holding the ProTape® in place, use the opposite hand to pull the handle all the way down until it snaps into the Clamp Roller. This attaches the ProTape® to the cutting mechanism. Finally, raise the handle into the upright position and discard the ProTape® section that's been cut away.

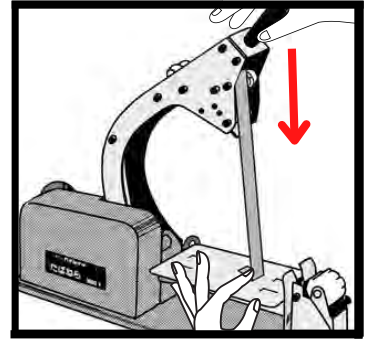

5 Bundling

Caution

To avoid injury or damage:

- Do not touch the cutting blade
- Always operate the device on a flat surface

1 Before bundling, ensure that the Receptacle Plate is in the correct position for the size of the product. When looking at the center of the Clamp Roller, you should see at least 1/4 of the product above the top of the Clamp Roller.

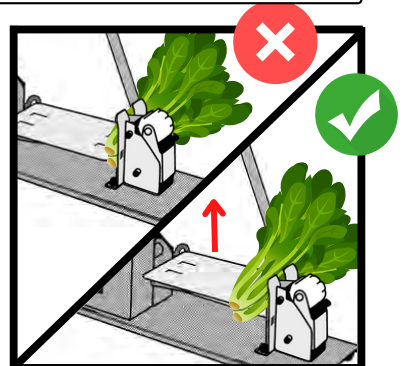

Adjust the height of the Receptacle Plate by removing the Plate Adjustment Pin. Once you've obtained the correct height, put the Plate Adjustment Pin back into place.

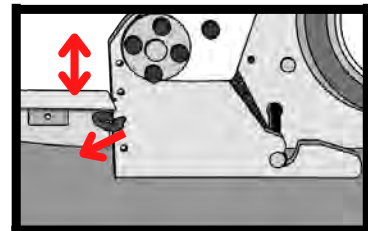

2 A. Align the product
Align the product in front of the attached strip of ProTape® (Fig. 1).

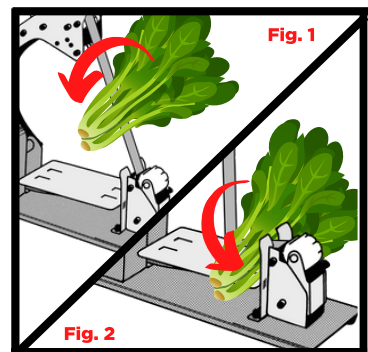

B. Push the product across and down

Push the product across the ProTape® and down toward the Receptacle Plate until it's firmly against the Guard Plate (Fig. 2).

C. Pull the handle down toward the Clamp Roller.

Ensure that the product does not cover or block the Clamp Roller. Push the handle down until it snaps into the Clamp Roller (Fig. 3), and then raise the handle back into the upright position.

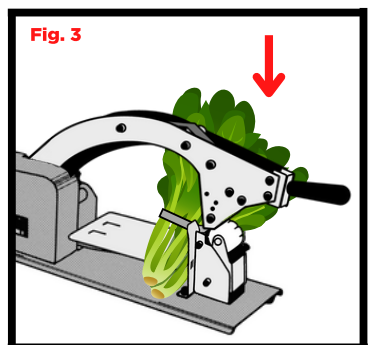

6 Troubleshooting

The tape is not cutting straight or at all.

- The cutting blade needs to be adjusted or replaced. Check the cutting blade's orientation as shown in Section B. "Replacing the Cutting Blade"

The tension is too tight or too loose.

- Tension is controlled by the Tension Spring. The tighter the spring, the greater the tension. Turning the tension nut in a clockwise direction gives more tension. Adjust the tension until the bundle has a good tight wrap. Tighten the lock nut against the tension nut so this tension will not change.
- If the bundle is still not tight enough, check the blade position to ensure a 1mm distance between the blade and the ratchet plate. To adjust the Blade Holder, loosen the two socket head cap screws, adjust the holder and then tighten the screws again.

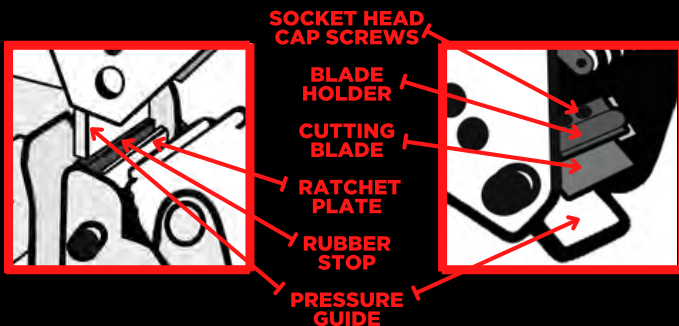

The ProTape® is jamming or leaving a tail in the machine.

- In order to make a good cut and keep the tape from jamming (or leaving a tail in the machine), it is necessary that the pressure guide is flush with the rubber stop when in the bundle position. If it is not, turn the 3000V on its side and loosen the 3 socket head cap screws. This will allow the entire assembly to be moved so the proper alignment can be achieved. Adjust as needed and tighten screws.

The ProTape® roll is not turning enough when bundling.

- If the ProTape® does not feed right because the roll is not turning enough when bundling, the Ratchet Pawl Stop may need adjusting.

Remove the side cover and pull the handle down and release it. If the Ratchet Pawl does not release when the handle is up, adjust the stop by loosening the bolt, moving the stop to the left and tightening the bolt.

RATCHET PAWL STOP

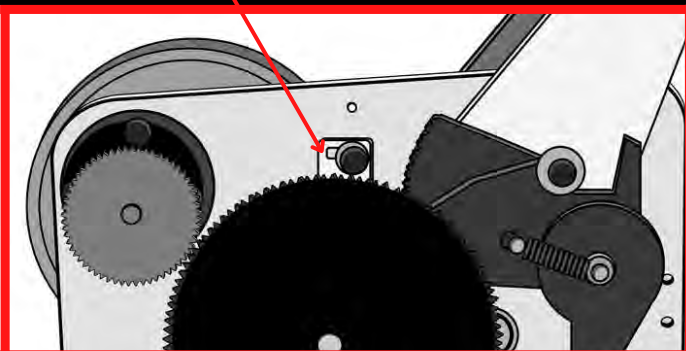

Maintenance

A Cleaning the 3000V

The 3000V can be cleaned with water, even to the point of spraying it off with a water hose.

- After cleaning, wipe dry.
- Oil the cutting blade to keep it from rusting.
- Remember, a clean machine is a happy machine!

+ Replacement Parts

Product Name	Cutting Blade
Item Number	09801
Blades / Pack	10
Product Image	 Notice: Please mention the item number when ordering replacements.

B Replacing the Cutting Blade

⚠ Caution

- Use only genuine ProTape® Dispenser replacement cutting blade.
- Ensure the ProTape® dispenser is on a flat surface (such as a table) at all times.
- Do not insert or remove blade with bare hands. Use the supplied pliers.
- Never touch the blade with your fingers as this may cause injury.

- Clean the blade edge prior to storage by wiping with alcohol or equivalent.
- Replace the cutting blade when the tape no longer cuts cleanly.
- Use the item number 09801 to order replacement blades.
- Dispose of used blades in accordance with local regulations.

- 1 The blade is held in place by a spring-loaded clamp located on the opposite side of the handle. Press down on the top of the clamp to lift the tape roller away from the blade.

- 2 With the supplied pliers, pull the blade straight down. Insert a new blade (making sure it is tight against the stop).

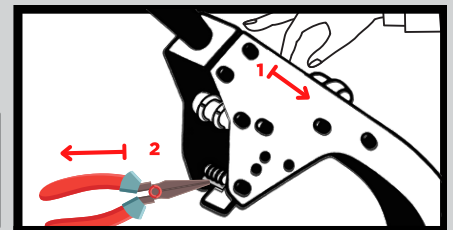

C Replacing the O-Rings

- 1 Press down on the spring-loaded clamp located on the opposite side of the handle to lift the tape roller up.
- 2 Push in on the pin that runs through the center of the tape roller and bracket assembly. Then remove the tape roller from the arms of the bracket (one side at a time) to replace the O-Rings. Once you've finished, simply return the tape roller to the brackets and push the pin back in place.

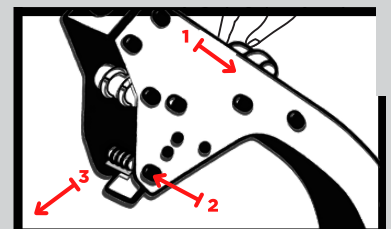

ProTape®
**3000V
DISPENSER**

Parts List

Part#	Part Name
1	Base
2	Rubber Foot
3	Scissors Stand
4	Scissors Arm Spindle
5	Scissors Arm
6	Scissors Cam Spindle
7	Scissors Cam
8	Scissors Spring
9	Hook Pin
10	Reverse Stop Latch
11	Reverse Stop Spring
12	Forward Stop Latch
13	Forward Stop Spring
14	Tacker Spindle
15	Tacker
16	Rubber Stop
17	Tape Guide
18	Plate 1 & 2 Assembly
19	Plate 1 Adjustment Pin
20	Bundling Arm Spindle
21	Bundling Arm
22	Handle Bracket
23	Handle
24	Handle Nut
25	Pressure Spring Spindle
26	Guide Roll
545	Bearing Case

Part#	Part Name
28	Guide Ring
29	Roll Arm Bracket
30	Roll Arm Spindle
31	O Ring Spindle
32	O Rings
33	Pressure Spring
34	Guide Roll Spindle
35	Blade Holder
39	Pressure Roll Arm
40	Pressure Roll Bracket
45	Drive Sector Spring
48	Ratchet Pawl Stop
49	Ratchet Gear
50	Ratchet Pawl
51	Ratchet Pawl Spring
52	Drive Gear
53	Tape Spindle
54	Cover
55	Bundle Arm Return Spindle
56	Bundle Arm Return Spring
71	Pressure Spring
102	Tape Holder
106	Tape Holding Tab
109	Brake Plate
111	Brake Spring
112	Tape Tension Adjustment Nut

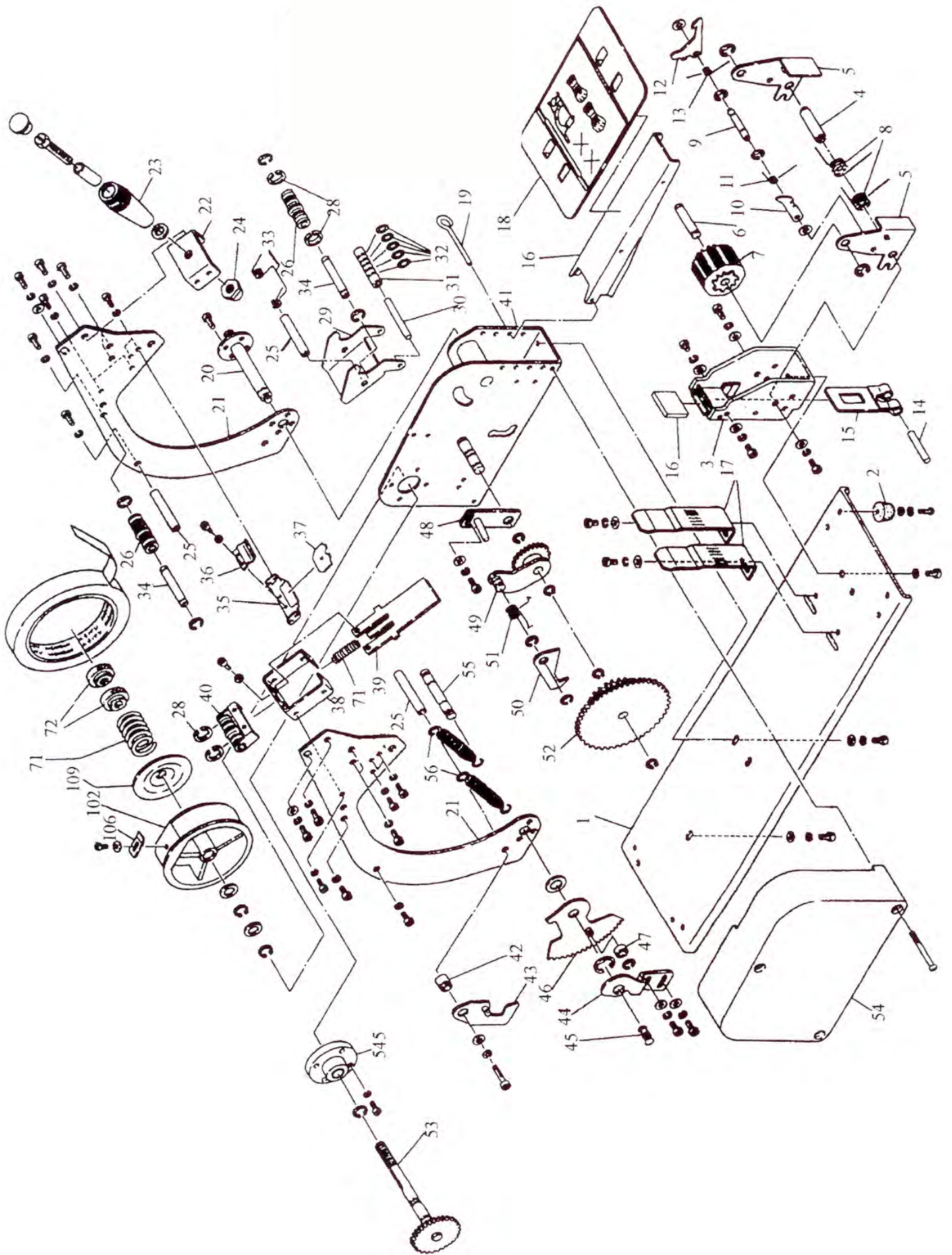

HOLDING YOUR WORLD
1923
TOGETHER SINCE



Alliance[®]
RUBBER COMPANY

800.626.5940 | www.RUBBERBAND.com | sales@alliance-rubber.com | ISO 9001:2015